

General Description

Silverliner[®] Open State Cavity Barrier (OSCB) systems have been developed to protect the voids between the outer façade and the inner construction element of the building. The product is designed for use in a ventilated façade, with a 25mm or 50mm linear air gap to allow the movement of air and drainage of any moisture within the facade.

The aluminium foil restricts fibre migration and offers a class '0' rating. In the event of a fire the intumescent outer edge of the product will expand and close the ventilation gap between the product and the façade preventing the passage of fire and smoke from one compartment to another.

Application and Use

- Between the inner substrate and the external building envelope
- In conjunction with Paraflam[®] where vertical Cavity Barriers are required
- Where movement of air and moisture is required
- Systems to cover void ranges from 2mm - 550mm

Key Product Advantages

- 3rd Party approved - IFCC - IFCC 1672
- Non-combustible core
- 'Dry fit' solution, no cure time
- Fast installation using brackets

Product Details

Total void size	≤ 550mm (see individual product pages)
Air Gap	≤ 50mm (see individual product pages)
Fire resistance	Up to 120 minutes tested in accordance with ASFP TGD 19 (see individual product pages)
Ventilation void closure time	≤ 5 minutes
Product dimensions	1000mm x 75mm (width is variable depending on building requirements)
	1000mm x 120mm (width is variable depending on building requirements)
Density	Mineral fibre 80kg/m ³
Brackets	Stainless Steel - 1.5mm / 0.9mm thickness, 390mm or 635mm length. For product size in excess of 300mm (w) use 635mm
Fixings	3 brackets per 1000mm @250mm centres (length 390mm or 635mm)
Pack Size / UOM	Various available—items supplied cut to size to suit project requirements. See individual product pages for depths.
Shelf Life	N/A—assumed working life of 25 years.

Technical Data Sheet

Testing

The FSi Silverliner® Open State Cavity Barrier (OSCB) range has been tested in accordance with ASFP TGD19: “Open State” Cavity Barrier used in External Envelope or Fabric of Buildings. This test method specifies a procedure for determining the fire resistance of ‘open state’ cavity barriers when subjected to the standard fire exposure conditions and performance criteria stipulated in EN 1363-1. This method is applicable to non-loadbearing, horizontally oriented open-state cavity barriers, which are used to provide fire separation within cavity voids such as those located between an external envelope and the face of a building. The tests have been undertaken to assess the ability of the Silverliner® OSCB systems to reinstate the fire resistance of rigid/aerated concrete supporting construction. This is the standard assembly for testing such systems as performance of the barriers can then be classified.

Product Certification / Approvals

Approval	Reference number
IFC	IFCC 1672

Testing / Classification

Standard	Description	Result
ASFP TGD19	“Open State” Cavity Barrier used in External Envelope or Fabric of Buildings utilising BS EN 1363-1:2012 and Principles of BS EN 1366-4 and Principles of BS EN 1366-4	30,60, 90 or 120 minutes fire resistance depending upon OSCB type and cavity size

Technical Data Sheet

Products

1. Silverliner® Open State Cavity Barrier 1
2. Stainless Steel Brackets
3. Paraflam® SEB

Maximum Void Size Performance (mins)

50 - 500mm *	Integrity: 90 Insulation: 30
--------------	---------------------------------

Maximum Air Gap Product Dimensions

25mm	Length: 1000mm Depth: 75mm
------	-------------------------------

Additional Notes

Fire Resistance

Silverliner® OSCB has been tested in accordance with ASFP TGD 19 Fire Resistance Test for Open-State Cavity Barriers used in the external envelope or fabric of buildings.

In the test a representative sample of an open state cavity barrier is exposed to a specified regime of heating and pressure as specified in EN 1363-1. The fire resistance performance of the test specimen is also monitored as stipulated by this standard and the results are expressed as the time for which the appropriate criteria have been satisfied.

* 50 - 77mm voids not included in the IFC 3rd Party Certificate Scope

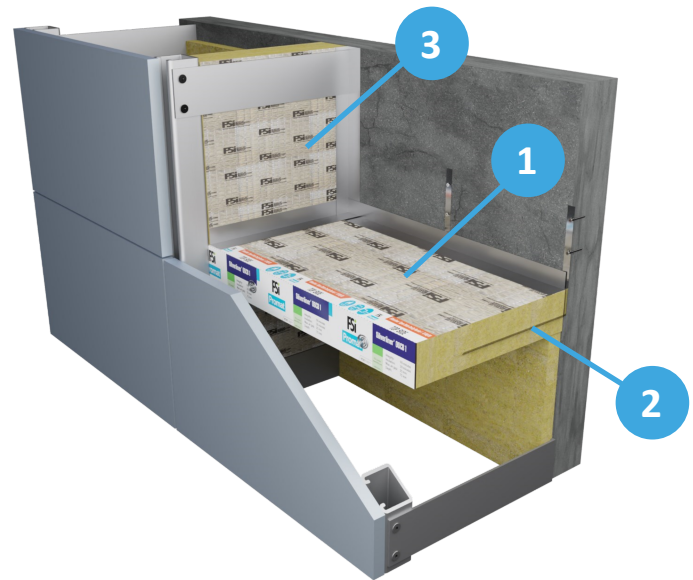

Installation

- Silverliner® OSCB cavity barrier is installed in the voids between the outer rainscreen facade and the inner construction element of the building.
- Any insulation fitted to the inner construction element of the building should be cut away where Silverliner® OSCB is to be installed.
- Specified stainless steel brackets should be fixed to substrate using suitable non-combustible fixings (if not using FSi brackets please seek technical advice for the suitability).
- 3 brackets per 1000mm piece should be fixed at 250mm, 500mm and 750mm.
- Silverliner® OSCB should be then placed on to the brackets. The brackets must span 75% of the width of the product.
- Once the Silverliner® OSCB is installed, tape over all joints/junctions with silver foil tape ensuring all abutting edges are sealed.
- When selecting length of bracket installers need to take into account the overall width of the product.



Technical Data Sheet

Products

1. Silverliner® Open State Cavity Barrier 2
2. Stainless Steel Brackets
3. Paraflam® SEB

Maximum Void Size Performance (mins)

54 - 350mm *	Integrity: 60 Insulation: 30
--------------	---------------------------------

Maximum Air Gap Product Dimensions

50mm	Length: 1000mm Depth: 75mm
------	-------------------------------

Additional Notes

Fire Resistance

Silverliner® OSCB has been tested in accordance with ASFP TGD 19 Fire Resistance Test for Open-State Cavity Barriers used in the external envelope or fabric of buildings.

In the test a representative sample of an open state cavity barrier is exposed to a specified regime of heating and pressure as specified in EN 1363-1. The fire resistance performance of the test specimen is also monitored as stipulated by this standard and the results are expressed as the time for which the appropriate criteria have been satisfied.

* 54 - 104mm voids not included in the IFC 3rd Party Certificate Scope

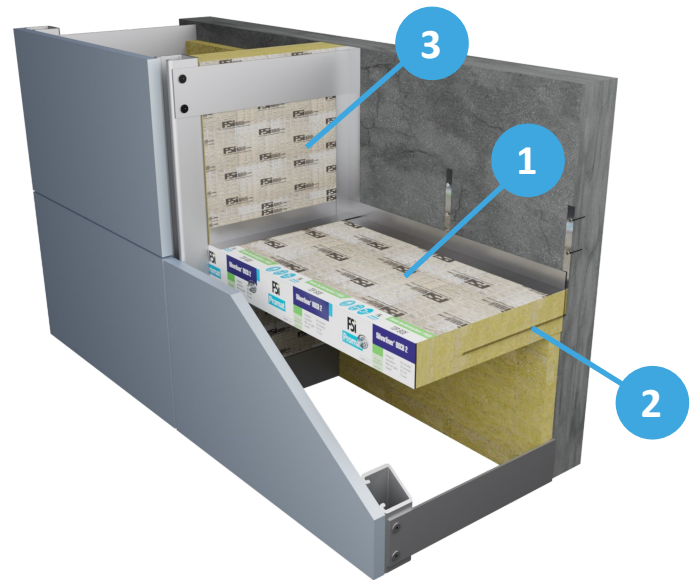

Installation

- Silverliner® OSCB cavity barrier is installed in the voids between the outer rainscreen facade and the inner construction element of the building.
- Any insulation fitted to the inner construction element of the building should be cut away where Silverliner® OSCB is to be installed.
- Specified stainless steel brackets should be fixed to substrate using suitable non-combustible fixings (if not using FSi brackets please seek technical advice for the suitability).
- 3 brackets per 1000mm piece should be fixed at 250mm, 500mm and 750mm.
- Silverliner® OSCB should be then placed on to the brackets. The brackets must span 75% of the width of the product.
- Once the Silverliner® OSCB is installed, tape over all joints/junctions with silver foil tape ensuring all abutting edges are sealed.
- When selecting length of bracket installers need to take into account the overall width of the product.



Technical Data Sheet

Products

1. Silverliner® Open State Cavity Barrier 3
2. Stainless Steel Brackets
3. Paraflam® SEB

Maximum Void Size Performance (mins)

52 - 527mm *	Integrity: 120 Insulation: 120
--------------	-----------------------------------

Maximum Air Gap Product Dimensions

25mm	Length: 1000mm Depth: 120mm
------	--------------------------------

Additional Notes

Fire Resistance

Silverliner® OSCB has been tested in accordance with ASFP TGD 19 Fire Resistance Test for Open-State Cavity Barriers used in the external envelope or fabric of buildings.

In the test a representative sample of an open state cavity barrier is exposed to a specified regime of heating and pressure as specified in EN 1363-1. The fire resistance performance of the test specimen is also monitored as stipulated by this standard and the results are expressed as the time for which the appropriate criteria have been satisfied.

* 50 - 77mm voids not included in the IFC 3rd Party Certificate Scope.

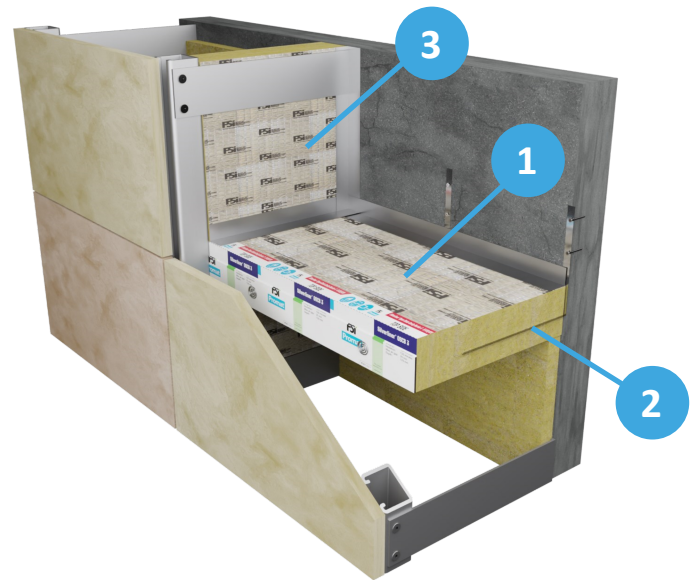

Installation

- Silverliner® OSCB cavity barrier is installed in the voids between the outer rainscreen facade and the inner construction element of the building.
- Any insulation fitted to the inner construction element of the building should be cut away where Silverliner® OSCB is to be installed.
- Specified stainless steel brackets should be fixed to substrate using suitable non-combustible fixings (if not using FSi brackets please seek technical advice for the suitability).
- 3 brackets per 1000mm piece should be fixed at 250mm, 500mm and 750mm.
- Silverliner® OSCB should be then placed on to the brackets. The brackets must span 75% of the width of the product.
- Once the Silverliner® OSCB is installed, tape over all joints/junctions with silver foil tape ensuring all abutting edges are sealed.
- When selecting length of bracket installers need to take into account the overall width of the product.



Technical Data Sheet

Products

1. Silverliner® Open State Cavity Barrier 4
2. Stainless Steel Brackets
3. Paraflam® SEB

Maximum Void Size Performance (mins)

54 - 354mm *	Integrity: 90 Insulation: 60
355 - 550mm	Integrity: 60 Insulation: 60

Maximum Air Gap Product Dimensions

50mm	Length: 1000mm Depth: 120mm
------	--------------------------------

Additional Notes

Fire Resistance

Silverliner® OSCB has been tested in accordance with ASFP TGD 19 Fire Resistance Test for Open-State Cavity Barriers used in the external envelope or fabric of buildings.

In the test a representative sample of an open state cavity barrier is exposed to a specified regime of heating and pressure as specified in EN 1363-1. The fire resistance performance of the test specimen is also monitored as stipulated by this standard and the results are expressed as the time for which the appropriate criteria have been satisfied.

* 54 - 104mm voids not included in the IFC 3rd Party Certificate Scope

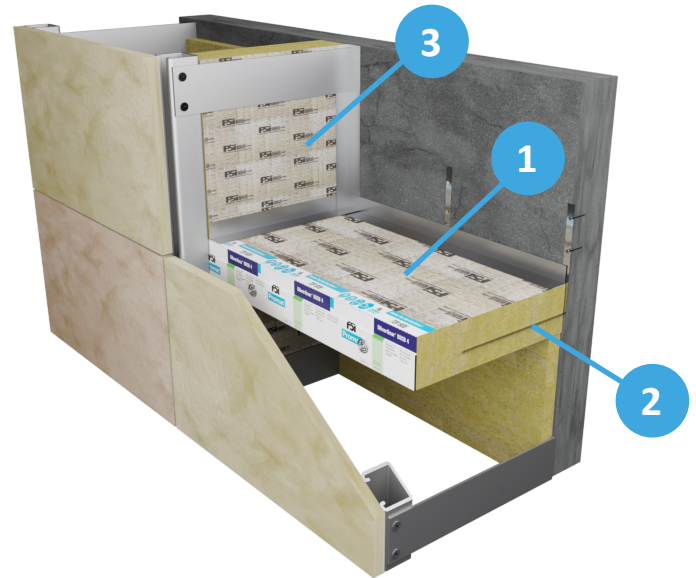

Installation

- Silverliner® OSCB cavity barrier is installed in the voids between the outer rainscreen facade and the inner construction element of the building.
- Any insulation fitted to the inner construction element of the building should be cut away where Silverliner® OSCB is to be installed.
- Specified stainless steel brackets should be fixed to substrate using suitable non-combustible fixings (if not using FSi brackets please seek technical advice for the suitability).
- 3 brackets per 1000mm piece should be fixed at 250mm, 500mm and 750mm.
- Silverliner® OSCB should be then placed on to the brackets. The brackets must span 75% of the width of the product.
- Once the Silverliner® OSCB is installed, tape over all joints/junctions with silver foil tape ensuring all abutting edges are sealed.
- When selecting length of bracket installers need to take into account the overall width of the product.



Technical Data Sheet

Products

1. Silverliner® Open State Cavity Barrier 5
2. Stainless Steel Brackets
3. Paraflam® SEB

Maximum Void Size Performance (mins)

52 - 527mm *	Integrity: 90 Insulation: 90
--------------	---------------------------------

Maximum Air Gap Product Dimensions

25mm	Length: 1000mm Depth: 120mm
------	--------------------------------

Additional Notes

Fire Resistance

Silverliner® OSCB has been tested in accordance with ASFP TGD 19 Fire Resistance Test for Open-State Cavity Barriers used in the external envelope or fabric of buildings.

In the test a representative sample of an open state cavity barrier is exposed to a specified regime of heating and pressure as specified in EN 1363-1. The fire resistance performance of the test specimen is also monitored as stipulated by this standard and the results are expressed as the time for which the appropriate criteria have been satisfied.

* 50 - 77mm voids not included in the IFC 3rd Party Certificate Scope.

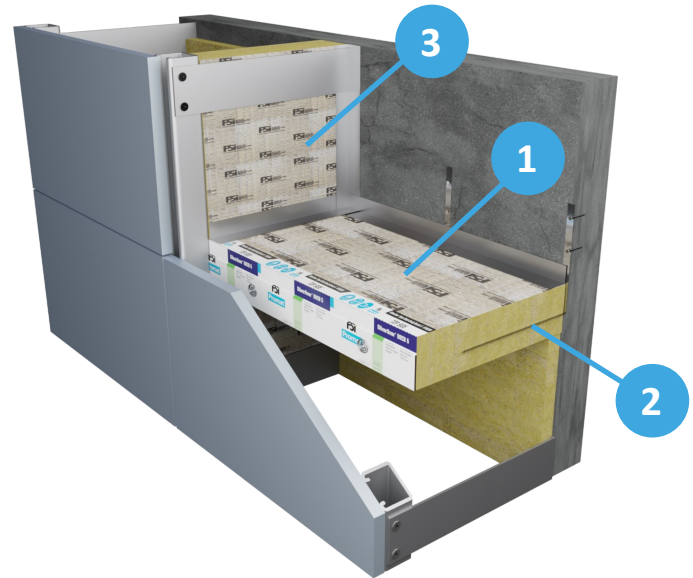

Installation

- Silverliner® OSCB cavity barrier is installed in the voids between the outer rainscreen facade and the inner construction element of the building.
- Any insulation fitted to the inner construction element of the building should be cut away where Silverliner® OSCB is to be installed.
- Specified stainless steel brackets should be fixed to substrate using suitable non-combustible fixings (if not using FSi brackets please seek technical advice for the suitability).
- 3 brackets per 1000mm piece should be fixed at 250mm, 500mm and 750mm.
- Silverliner® OSCB should be then placed on to the brackets. The brackets must span 75% of the width of the product.
- Once the Silverliner® OSCB is installed, tape over all joints/junctions with silver foil tape ensuring all abutting edges are sealed.
- When selecting length of bracket installers need to take into account the overall width of the product.



Technical Data Sheet

Products

1. Silverliner® Open State Cavity Barrier X 25
2. 75 mm long x 8 mm diameter non-combustible screw bolts

Maximum Void Size	Performance (mins)
-------------------	--------------------

2 - 27mm	Integrity: 90 Insulation: 60
----------	---------------------------------

Maximum Air Gap	Product Dimensions
-----------------	--------------------

25mm	Length: 25000mm Depth: 75mm
------	--------------------------------

Additional Notes

Fire Resistance

Silverliner® OSCB has been tested in accordance with ASFP TGD 19 Fire Resistance Test for Open-State Cavity Barriers used in the external envelope or fabric of buildings.

In the test a representative sample of an open state cavity barrier is exposed to a specified regime of heating and pressure as specified in EN 1363-1. The fire resistance performance of the test specimen is also monitored as stipulated by this standard and the results are expressed as the time for which the appropriate criteria have been satisfied.



Installation

- Silverliner® OSCB X 25 - is 2mm thick x 75mm wide intumescent strip designed to be installed in the voids between the outer rainscreen facade and the inner construction element of the building.
- OSCB X 25 is supplied in the form of a 25000mm roll for ease of use and versatility.
- Unroll the necessary length of Silverliner® OSCB X 25 as required and remove the plastic strip from adhesive side of OSCB X 25 prior to installation.
- 75 mm long x 8 mm diameter non-combustible screw bolts must be used to fix the OSCB X 25 directly to the inner element of construction where Fire Resistance is required, at a maximum 250mm centres ensuring the screed side is facing inwards.

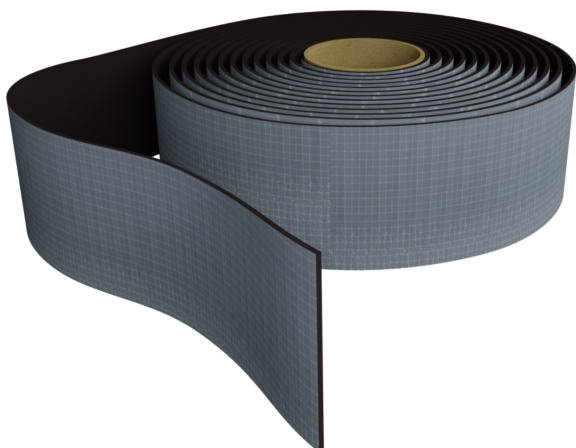

Technical Data Sheet

Products

1. Silverliner® Open State Cavity Barrier X 50
2. 75 mm long x 8 mm diameter non-combustible screw bolts

Maximum Void Size	Performance (mins)
-------------------	--------------------

4 - 54mm	Integrity: 60 Insulation: 30
----------	---------------------------------

Maximum Air Gap	Product Dimensions
-----------------	--------------------

50mm	Length: 12500mm Depth: 75mm
------	--------------------------------

Additional Notes

Fire Resistance

Silverliner® OSCB has been tested in accordance with ASFP TGD 19 Fire Resistance Test for Open-State Cavity Barriers used in the external envelope or fabric of buildings.

In the test a representative sample of an open state cavity barrier is exposed to a specified regime of heating and pressure as specified in EN 1363-1. The fire resistance performance of the test specimen is also monitored as stipulated by this standard and the results are expressed as the time for which the appropriate criteria have been satisfied.



Installation

- Silverliner® OSCB X 50 - is 4mm thick (2x2mm) x 75mm wide intumescent strip designed to be installed in the voids between the outer rainscreen facade and the inner construction element of the building.
- OSCB X 50 is supplied in the form of a 25000mm roll for ease of use and versatility.
- Unroll the necessary length of Silverliner® OSCB X 50 as required and remove the plastic strip from adhesive side of OSCB X 50 prior to installation.
- 75 mm long x 8 mm diameter non-combustible screw bolts must be used to fix the OSCB X 50 directly to the inner element of construction where fire resistance is required, at a maximum 250mm centres ensuring the screed side is facing inwards

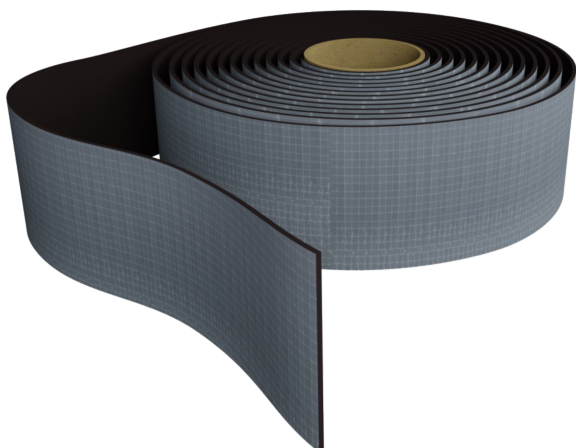

Technical Data Sheet

Handling, Storage & Disposal

For information and advice on the safe handling, storage and disposal of chemical products, please refer to the most recent Safety Data Sheet (SDS) available at www.fsiltd.com

Maintenance

No active maintenance is required for the FSi Promat Silverliner OSCB range, please ensure the product is visually checked to ensure the products are installed as per the FSi installation guidance and in line with the approved project design as per the instructions at the time of the original installation.

Installation

Ensure the products are installed in line with manufacturers' installation guidelines

Legal Notes

FSi Ltd. products are manufactured to rigid standards of quality. Any product which has been applied in accordance with FSi Ltd.'s written instructions and in any application recommended by FSi Ltd., but which is proved to be defective in product quality, will be replaced free of charge. No liability can be accepted for the information provided in this document although it is published in good faith and believed to be correct at time of issue. Any drawings provided are for illustrative purposes only. FSi Ltd. reserves the right to alter product specifications without prior notice, in line with our Company policy of continuous development and improvement. Changes due to new findings are possible, errors and misprints are not excluded. No liability whatsoever will be accepted for any loss, damage or injury arising from the use of the information given. FSi Ltd. have no control over the methods of installation, competence of operatives or suitability of site conditions, no warranties, expressed or implied, are intended to be given as to the actual performance of the product/system mentioned within this document.

FSi Limited

Westminster Industrial Estate
Tamworth Road
Measham
DE12 7DS
Tel: +44 (0)1530 515130
Email: technical.fsi.uk@etexgroup.com
Web: www.promat.com/en-gb