

BY
YOUR
SIDE®

Version 4.22 November 2021

RH & RV CAVITY BARRIERS

For use in external envelope
or fabric of buildings

RH & RV CAVITY BARRIERS

Siderise RH and RV 'Open State' cavity barriers have been specifically developed to meet the requirements for cavity barriers used in drained and ventilated façades. Their use ensures that the system will drain any moisture within the façade construction, whilst maintaining airflow and, in the event of fire, provide an effective hot smoke and fire seal.

Siderise RH 'Open State' horizontal and RV vertical cavity barrier range represent the default choice for market-leading, high-performance Rainscreen Cavity Barrier applications.

- Allows continuous ventilation and drainage behind the external envelope
- Products tested in isolation and in large-scale system tests
- Reactive intumescent has rapid seal closure properties
- Horizontal barriers can incorporate up to 50mm continuous ventilated air space
- Vertical barriers accommodate cladding serviceability movement

Siderise RH Horizontal cavity barriers: Siderise has developed two 'Open State' (open void) horizontal solutions: RH25(G/S) for air gaps up to 25mm and RH50(G/S) for air gaps up to 50mm.

Siderise RH Horizontal cavity barriers may be used with a number of cladding types (for example: trapezoidal, sinusoidal, ribbed and seamed), however the maximum

gap at any point must not exceed the stated 'air gap' – e.g. 25mm for RH25 and 50mm for RH50. For panels outside of these limits please contact Siderise.

The product range is compliant to current market requirements and has been tested to ASFP Guidance: 'Open State' Cavity Barrier used in External Envelope or Fabric of Buildings, utilising principles of EN 1363-1. ASFP Technical Guidance Document – TGD 19 (July 2014 revised Nov 2017) refers.

Siderise RV vertical cavity barriers for rainscreen cladding are used to full fill the void between the external envelope and internal structure.

By fully sealing the void they assist ventilated façades to function by maintaining air-pressurisation compartmentation.

Significantly, their unique stonewool lamella core construction enables the vertical barriers to accommodate the serviceability movement normally associated with rainscreen façades.

Intersections between horizontal and vertical cavity barriers are simply abutted.



250 City Road, London
Front cover: One Tower, Limassol

SIDERISE RH OPEN STATE HORIZONTAL CAVITY BARRIERS

Product description

Siderise RH 'Open State' horizontal cavity barriers consist of a non-combustible stonewool lamella core, with reinforced aluminium foil faces. This primary seal has a reaction to fire performance to Class 'A1'. The exposed leading edge is also sealed with aluminium foil.

Whilst the base material is water repellent and non-hygroscopic, this predominantly enclosed arrangement affords an added degree of weather protection to the core material.

Siderise RH 'Open State' horizontal cavity barriers incorporate a continuous high performance reactive intumescent strip which is bonded to the leading edge. The intumescent material has a reaction to fire performance to Class 'E'. In the event of exposure to fire, the intumescent rapidly expands and fully seals the purposely designed ventilation gap formed at the time of installation between barrier and the rear of the cladding.

As standard, the range includes a choice of products to suit either 25mm air gaps – referred to as RH25 – or 50mm air gaps – referred to as RH50. Both options are available with either galvanised mild steel (G) or stainless steel (S) fixing brackets as part of the system.

The specific horizontal cavity barrier system is then referred to as either RH25G, RH25S, RH50G or RH50S accordingly. The choice of bracket is usually determined by the rainscreen system designer according to project exposure and/or location.

The leading edge of the horizontal cavity barrier is encapsulated in a weather resistant polymer film. As standard, the film is black so as to register as a 'shadow-line' behind open joints in the cladding.

For product identification purposes, the top edges of the film used on the RH25 and RH50 cavity barriers are colour-coded and labelled to show the product fire classification rating.

Siderise RH 'Open State' horizontal cavity barrier for air gaps up to 25mm

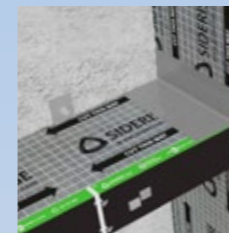

RH25-90/30



RH25-60/60

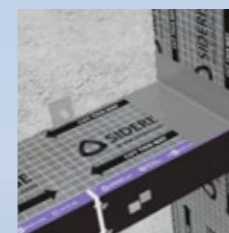

RH25-90/60



RH25-120/60



RH25-120/90

Siderise RH 'Open State' horizontal cavity barrier for air gaps up to 50mm



RH50-30/30



RH50-60/60

Product	Rating			Colour
RH25 - 90/30	E90	I30	EI30	Green
RH25 - 60/60	E60	I60	EI60	Orange
RH25 - 90/60	E90	I60	EI60	Purple
RH25 - 120/60	E120	I60	EI60	Yellow
RH25 - 120/90	E120	I90	EI90	Grey
RH50 - 30/30	E30	I30	EI30	Red
RH50 - 60/60	E60	I60	EI60	Blue

SIDERISE RH OPEN STATE HORIZONTAL CAVITY BARRIERS

Standards and approvals

Siderise 'Open State' horizontal cavity barriers satisfy the requirements of:

- **England** – The Building Regulations 2010, Approved Document B (2019 edition) Volume 2, Section 9, diagram 9.1 and item 9.13 (Provision for cavity barriers requires 30 minutes Integrity and 15 minutes Insulation).
- **Wales** – The Building Regulations 2010, Approved Document B (Provision for cavity barriers requires 30 minutes Integrity and 15 minutes Insulation).
- **Scotland** – Technical Handbook 2. (Provision for cavity barriers requires 30 minutes Integrity only).
- **Northern Ireland** – Technical Document E. (Provision for cavity barriers requires 30 minutes Integrity and 15 minutes Insulation).
- **Ireland** – Technical Guidance Document B. (Provision for cavity barriers requires 30 minutes Integrity and 15 minutes Insulation).

They also meet the higher minimum fire resistance standard for cavity barriers outlined in the **LPC Design Guide for the Fire Protection of Buildings**. (Provision for cavity barriers requires 30 minutes Integrity and 30 minutes Insulation).

Fire testing – products

Siderise 'Open State' horizontal cavity barriers have been tested in accordance with ASFP TGD19 (prEN 1364-6): 'Open State' Cavity Barrier used in External Envelope or Fabric of Buildings. This test method specifies a procedure for determining the fire resistance of 'open state' cavity barriers when subjected to the

standard fire exposure conditions and performance criteria stipulated in EN 1363 Part 1: 2012.

The tests have been undertaken to assess the ability of the horizontal 'open state' cavity barrier products to reinstate the fire resistance of a pre-cast, aerated concrete supporting construction. This is the standard assembly for testing such cavity barrier products as it allows the performance of the individual barrier to be classified.

Product fire performance

Siderise RH25(G/S) 'Open State' horizontal cavity barrier for maximum 25mm air gaps

Siderise have tested horizontal cavity barriers with 25mm air gap to the ASFP TGD19 method. During the fire tests, the seals achieved full effective closure in under 2.5 minutes. Seal temperatures remained below 180°C during this activation period and maintained the EI requirements as detailed in Tables 1 & 2 for up to EI20 and I90.

Siderise RH50(G/S) EI30 'Open State' horizontal cavity barrier for maximum 50mm air gaps, 30 minutes Integrity and 30 minutes Insulation

Siderise have tested horizontal cavity barriers with 50mm air gap to the ASFP TGD19 method. During the fire tests, the seals achieved full effective closure in under 2.5 minutes. Seal temperatures remained below 180°C during this activation period and maintained the EI requirements as detailed in Tables 1 & 2 for up to EI30.

Siderise RH50(G/S) EI60 'Open State' horizontal cavity barrier for maximum 50mm air gaps, 60 minutes Integrity and 60 minutes

Insulation

Siderise have tested horizontal cavity barriers with 50mm air gap to the ASFP TGD19 method. During the fire tests, the seals achieved full effective closure in under 2.5 minutes. Seal temperatures remained below 180°C during this activation period and maintained the EI requirements as detailed in Tables 1 for up to EI60.

Small voids

For small voids <48mm please refer to Table 2 for fire classification performance up to EI20 and I90.

System fire performance

Siderise cavity barrier products have been used in a number of large-scale system tests such as BS 8414 (1&2) and NFPA 285. These may be used to evaluate the performance of the Siderise cavity barriers within a complete cladding system. The rules for evaluation of results from BS 8414 are subsequently defined in BS 9414.

For information regarding performance and assembly details in system tests please contact the Technical team. technical.services@siderise.com

Table 1

Fire classification performance for Siderise RH 'Open State' horizontal cavity barriers with galvanised and stainless steel brackets for voids between 49 – 425mm (RH25) and 60 – 300mm (RH50)

Product type	Product fire classification rating			Barrier dimensions T x W (mm)	Void range (mm)	Air gap (mm)
	Integrity (E)	Insulation (I)	Classification (EI)			
RH25G-90/30	90	30	30	75 x void -25	27 – 425	25±3.0
RH25G-60/60	60	60	60	90 x void -25	27 – 425	25±3.0
RH25G-90/60	90	60	60	90 x void -25	27 – 300	25±3.0
RH25G-120/60	120	60	60	120 x void -25	27 – 425	25±3.0
RH25G-120/90	120	90	90	120 x void -25	27 – 425	25±3.0
RH50G-30/30	30	30	30	75 x void -50	60 – 300	50±5.0
RH50G-60/60	60	60	60	90 x void -50	60 – 300	50±5.0

Please note:

'T' refers to barrier thickness. 'W' refers to barrier width.

Fire classification rating in the above tables refers to performance in product fire tests in accordance with the ASFP TGD19 test method. The products have been additionally incorporated in large scale system tests. Please contact the Technical Services team for further information. In all cases, we recommend that the specifier and user review the specific project configuration with regard to available large scale system test data and in light of the latest National Building Regulations, local Code and/or government advice.

SIDERISE RH OPEN STATE HORIZONTAL CAVITY BARRIERS

Table 2
Fire classification performance for Siderise 'Open State' horizontal cavity barriers for voids up to 50mm

Product type	Product fire classification rating			Barrier dimensions T x W (mm)	Void range (mm)	Air gap (mm)
	Integrity (E)	Insulation (I)	Classification (EI)			
RH25-120/90*	120	90	90	15 x 75	0 - 26	25±3.0
				20 x 75	42 - 48	25±3.0
RH25-90/30	90	30	30	15 x 75	37 - 41	25±3.0
				15 x 75	32 - 36	20±3.0
				15 x 75	27 - 31	15±3.0
				20 x 90	42 - 48	25±3.0
RH25-60/60	60	60	60	15 x 90	37 - 41	25±3.0
				15 x 90	32 - 36	20±3.0
				15 x 90	27 - 31	15±3.0
				20 x 90	42 - 48	25±3.0
				15 x 90	37 - 41	25±3.0
RH25-90/60	90	60	60	15 x 90	32 - 36	20±3.0
				15 x 90	27 - 31	15±3.0
				20 x 120	42 - 48	25±3.0
				15 x 120	37 - 41	25±3.0
RH25-120/60	120	60	60	15 x 120	32 - 36	20±3.0
				15 x 120	27 - 31	15±3.0
				20 x 120	42 - 48	25±3.0
				15 x 120	37 - 41	25±3.0
RH25-120/90	120	90	90	15 x 120	32 - 36	20±3.0
				15 x 120	27 - 31	15±3.0
				20 x 120	42 - 48	25±3.0
				15 x 120	37 - 41	25±3.0

* Intumescent strip only.

Installation recommendations

Siderise RH25(G/S) 'Open State' horizontal cavity barrier for maximum 25mm air gaps

These cavity barriers are installed in the void formed between the rainscreen façade and the inner structural wall using the appropriate screw fixings or **Siderise support brackets** (see Tables 3-5).

To prevent fire flanking to the rear of the fire stop, any thermal insulation fitted to the outer face of the structural wall must be completely cut away to accommodate the thickness of this product.

The RH25(G/S) horizontal cavity barrier is fitted with the plain mineral fibre edge against the structural wall. A 25mm ±3mm (dimension may alter with specific design criteria) clear air gap should be left between the front edge of the cavity barrier and the rear surface of the rainscreen façade.

Adjacent lengths of the horizontal cavity barrier should be tightly abutted to prevent gaps. The top surface of the joint should be sealed with **Siderise Aluminium Jointing Tape**.

Siderise RH50(G/S) 'Open State' horizontal cavity barrier for maximum 50mm air gaps

These cavity barriers are installed in the void formed between the rainscreen façade and the inner structural wall using the appropriate screw fixings or **Siderise support brackets** (see Table 4).

To prevent fire flanking to the rear of the fire stop, any thermal insulation fitted to the outer face of the structural wall must be completely cut away to accommodate the thickness of this product.

The RH50(G/S) horizontal cavity barrier is fitted with the plain mineral fibre edge against the structural wall. A 50mm ±5mm (dimension may alter with specific design criteria) clear air gap should be left between the front edge of the cavity barrier and the rear surface of the rainscreen façade.

Adjacent lengths of the horizontal cavity barrier should be tightly abutted to prevent gaps. The top surface of the joint should be sealed with **Siderise Aluminium Jointing Tape**.

It is essential that the intumescent is installed as a continuous line passing in front of supporting rails.

A video providing further installation guidance is available online at www.siderise.com.

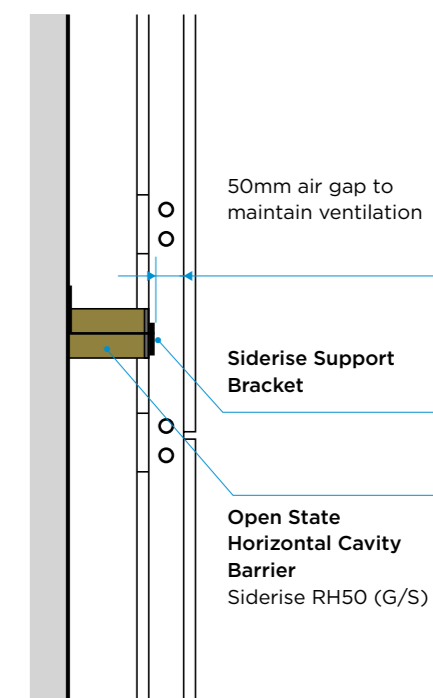
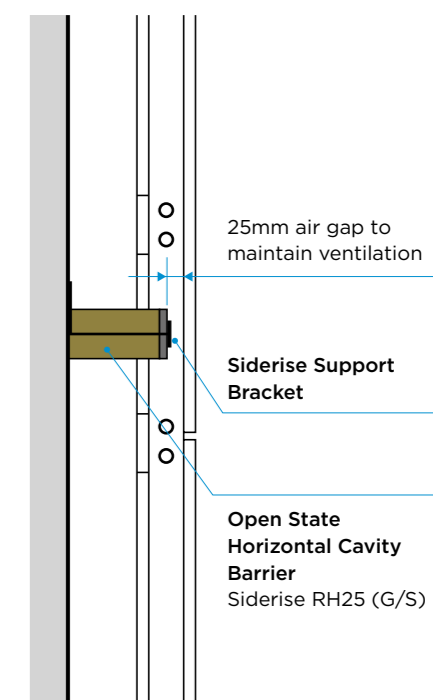

SIDERISE RH OPEN STATE HORIZONTAL CAVITY BARRIERS

Support brackets

A range of Siderise support brackets for horizontal cavity barriers are available for void widths of up to 425mm for 25mm air gaps or up to 300mm for 50mm air gaps (see Table 4). For voids of 0-75mm fixing screws are required, see Table 4, note these are not supplied by Siderise and should be non-combustible and suitable for substrate.

Lengths of the barrier are secured with these dedicated 'split' fixing brackets, which are impaled through the product at mid thickness.

The brackets are drilled on site and secured to the inner structural wall using non-combustible steel anchors or screws. These fixings are not supplied by Siderise.

Please note:

For cut lengths a minimum of 2 brackets per length must be used. When using Siderise support brackets, pre-fitting the brackets to the product is recommended prior to fixing to the wall. For cut lengths <100mm one bracket/length.

'Screws' refers to the fixing and a washer with a 15mm (max) head diameter. They should be non-combustible and suitable for substrate. These fixings are not supplied by Siderise.

Siderise RH25(G/S)

'Open State' horizontal cavity barrier for maximum 25mm air gaps (See Table 4)

To facilitate bracket penetration, a small horizontal cut should be made in the face intumescent strip coinciding with the bracket's exit point.

The protruding split ends should be trimmed to 10-20mm and counter-folded to retain the product.

Table 3

Screw fixing requirements for voids less than 75mm
For installation of Siderise RH25 'Open State' horizontal cavity barriers for small voids

Product type	Voids		
	0 - 75		
	Quantity	Type	Centres (mm)
RH25-120/90*	3	Screw	400
RH25-90/30	3	Screw	400
RH25- 60/60	3	Screw	400
RH25-90/60	3	Screw	400
RH25-120/60	3	Screw	400
RH25- 120/90	3	Screw	400

* Intumescent strip only

Please note:

Fixing screws are not supplied by Siderise

Siderise RH50(G/S)

'Open State' horizontal cavity barrier for maximum 50mm air gaps (See Table 4)

Siderise RH50(G/S) EI30 and RH50 (G/S) EI60 must be installed with product logo tape on the top face. This is to ensure that the intumescent is located at the bottom of the barrier, thus closest to fire.

The protruding split ends should be trimmed to 10-20mm and counter-folded to retain the product.

Table 4

Fixing requirements for installation of Siderise RH 'Open State' horizontal cavity barriers with galvanised and stainless steel brackets

Product type	Voids (mm)											
	27 - 75			76 - 250			251 - 350			351 - 425		
	Quantity	Type	Centres (mm)	Quantity	Type	Centres (mm)	Quantity	Type	Centres (mm)	Quantity	Type	Centres (mm)
RH25G-90/30	3	Screw	400	3	RS 350	400	3	RS 450	400	3	RS 550	400
RH25G-60/60	3	Screw	400	3	RS 350	400	3	RS 450	400	3	RS 550	400
RH25G-90/60*	3	Screw	400	3	RS 350	400	3	RS 450	400	N/A	N/A	N/A
RH25G-120/60	3	Screw	400	3	RS 350	400	3	RS 450	400	3	RS 550	400
RH25G-120/90	3	Screw	400	3	RS 350	400	3	RS 450	400	3	RS 550	400
	60 - 75			76 - 250			251 - 300					
RH50G-30/30	3	Screw	400	3	RS 350	400	3	RS 450	400	N/A	N/A	N/A
RH50G-60/60	3	Screw	400	3	RS 350	400	3	RS 450	400	N/A	N/A	N/A

Please note:

Fixing screws are not supplied by Siderise.

*RH25-90/60 is only suitable for voids up to 300mm. Please refer to Table 1 for Fire Performance

Siderise RH horizontal cavity barriers are installed so that they terminate each side of the RV vertical cavity barriers.

SIDERISE RV VERTICAL CAVITY BARRIERS

Product description

Siderise RV vertical cavity barriers for rainscreen cladding applications consist of a non-combustible stonewool lamella core, with reinforced aluminium foil faces, giving an overall reaction to fire performance to Euro Class 'A1'.

The exposed leading edge is also sealed with aluminium foil. Whilst the base material is water repellent and non-hygroscopic, this predominantly enclosed arrangement affords an added degree of weather protection to the core material.

Siderise RV vertical cavity barriers are used to full fill the void between the external envelope and internal structure. The leading edge compresses directly against the external envelope, therefore no intumescent strip is required.

The construction offers an excellent resistance to the passage of both smoke and fire. Additionally, by fully sealing the void, they assist ventilated façades to function by maintaining air-pressurisation compartmentation.

Importantly, the Siderise RV vertical cavity barriers unique stonewool lamella core construction enables the vertical barriers to accommodate the serviceability movement normally associated with rainscreen façades.



Siderise RV vertical cavity barrier



SIDERISE RV VERTICAL CAVITY BARRIERS

Standards and approvals

Siderise RV vertical cavity barriers satisfy the requirements of:

- **England and Wales** – the Building Regulations 2000, Approved Document B (2006 edition), Appendix A, Table A1, item 10 (Volume 1) & item 15 (Volume 2) and diagram 33 (Provision for cavity barriers requires 30 minutes Integrity and 15 minutes Insulation).
- **Northern Ireland** – Technical Document E. (Provision for cavity barriers requires 30 minutes Integrity and 15 minutes Insulation).
- **Ireland** – Technical Guidance Document B. (Provision for cavity barriers requires 30 minutes Integrity and 15 minutes Insulation).
- **Scotland** – Technical Handbook 2. (Provision for cavity barriers requires 30 minutes Integrity only).

They also meet the higher minimum fire resistance standard for cavity barriers outlined in the LPC Design Guide for the Fire Protection of Buildings. (Provision for cavity barriers requires 30 minutes Integrity and 30 minutes Insulation).

Fire testing – products

Siderise RV vertical cavity barriers have been tested in accordance with EN 1366-4:2006 + A1:2010.

The tests have been undertaken to assess the ability of the vertical cavity barrier products to reinstate the fire resistance of a lightweight aerated concrete supporting construction. This is the standard assembly for testing such cavity barrier products as it allows the performance of the individual barrier to be classified.

Product fire performance

Siderise RV vertical cavity barriers fire performance is based on testing to EN 1366-4:2006 + A1:2010.

The cavity barriers maintained the E and I requirements as detailed in Table 5.

System fire performance

Siderise cavity barrier products have been used in a number of large-scale system tests such as BS 8414(1&2) and NFPA 285. These may be used to evaluate the performance of the Siderise cavity barriers within a complete cladding system.

For information regarding performance and assembly details in system tests please contact the Façades team.

Installation recommendations

Siderise RV vertical cavity barriers are installed within the cavity formed between the rainscreen façade and the inner structural wall using the appropriate **Siderise support brackets** (see Table 6).

The RV cavity barrier is fitted under compression to completely fill the void. For voids up to 50mm a nominal 5mm compression is required, for voids greater than 50mm a nominal 10mm compression is required. The product is installed with the plain mineral fibre edge positioned against the structural wall.

To prevent fire flanking to the rear of the fire stop, any thermal insulation fitted to the outer face of the structural wall must be completely cut away to accommodate the thickness of the vertical cavity barrier.

Adjoining lengths of this product should be tightly abutted to prevent gaps. Joints should be sealed with **Siderise foil tape RFT 120/45** to both sides.

A video is available on the website which provides further guidance on the installation of Siderise RH and RV cavity barriers.

Support brackets

A range of **Siderise support brackets** for the vertical cavity barriers are available for cavity widths of up to 450mm (see Table 6). Lengths of the barrier are supported with these dedicated brackets which impale the product at mid thickness to depth 75% of void and installed at 600mm fixing centres (300mm from each end).

The brackets are supplied as standard in 1mm galvanised mild steel in a flat form for folding on site and incorporate pre-notched indents to aid this process.

The brackets are drilled on site and secured to the inner structural wall using non-combustible steel anchors or screws. These fixings are not supplied by Siderise.

Table 5
Fire performance for Siderise RV vertical cavity barriers

Product type	Product fire classification			Thickness (mm)	Void range (mm)
	Integrity (E)	Insulation (I)	Classification (EI)		
RV-90/30	90	30	30	75	26 - 450
RV-90/60	90	60	60	90	26 - 450
RV-120/120	120	120	120	120	26 - 450

Please note:
Fire classification rating in the above tables refer to performance in product fire tests to EN 1366-4:2006 + A1:2010. The products have been additionally incorporated in large scale system tests. Please contact the Façades team for further information. In all cases, we recommend that the specifier and user reviews the specific project configuration with regard to available large-scale system test data and in light of the latest National Building Regulations, local Code and/or government advice. For voids than greater than 450mm, please contact the Façades team for further information.

Table 6
Brackets and centres for installation of Siderise vertical cavity barriers

Product type	Voids (mm)									
	20 - 50		51 - 150		151 - 240		241 - 300		301 - 450	
RV-90/30	N/A	N/A	B65/110	600 Ctrs	B195	600 Ctrs	B355	600 Ctrs	B355	600 Ctrs
RV-90/60	N/A	N/A	B65/110	600 Ctrs	B195	600 Ctrs	B355	600 Ctrs	B355	600 Ctrs
RV-120/120	N/A	N/A	B65/110	600 Ctrs	B195	600 Ctrs	B355	600 Ctrs	B355	600 Ctrs

Please note:
For voids less than 50mm: measured cavity + 5mm compression is required; for voids greater than 100mm: measured cavity +10mm compression is required.
Siderise RH horizontal cavity barriers are installed so that they terminate each side of the RV vertical cavity barriers.

SIDERISE RV VERTICAL CAVITY BARRIERS

Compartmentation: Approved Document B, 2006 edition, Volume 2. England and Wales

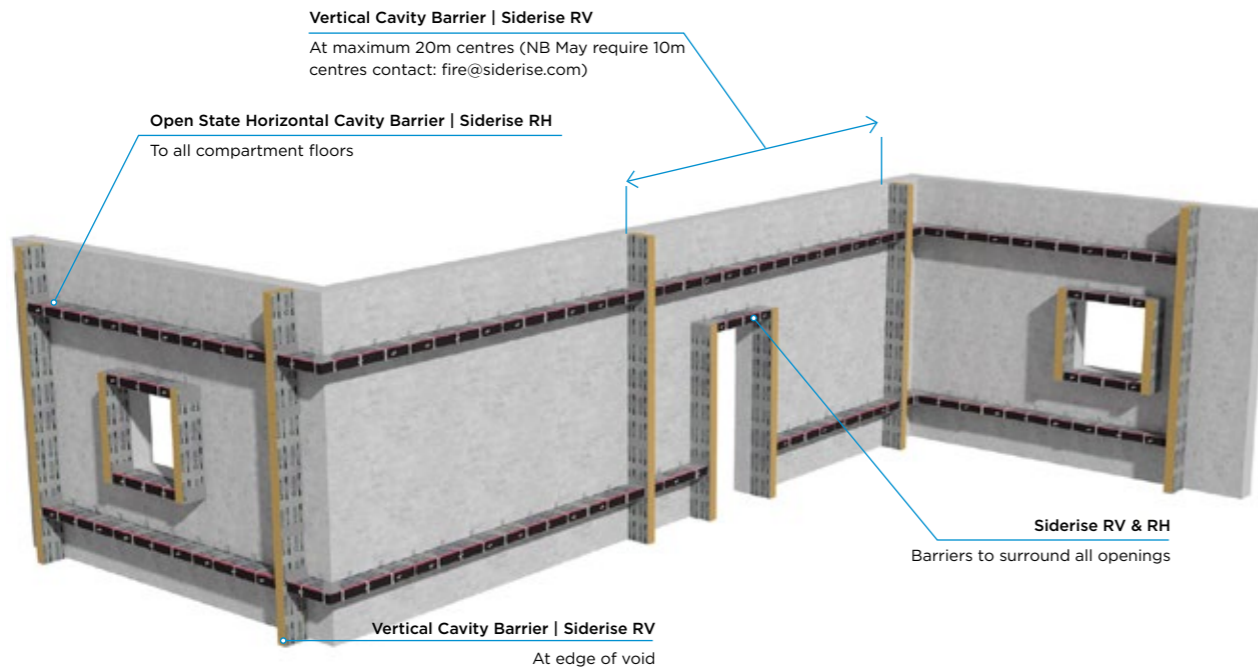

Compartmentation: NHBC guidelines

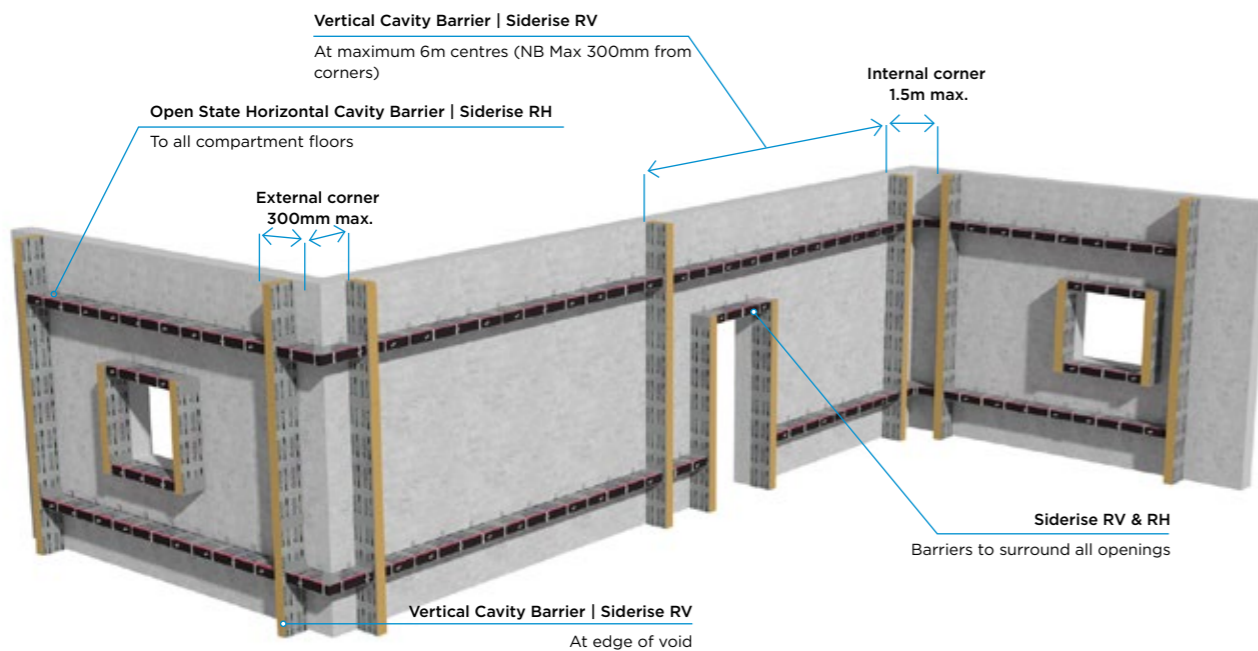

Please note:
The above illustrations reflect typical cavity barrier locations and are presented for guidance purposes only. The specifier and user must seek formal approval regarding cavity barrier location requirements on a project basis.

Table 7

Extract from Approved Document B Table 13: Maximum dimensions of cavities in non-domestic buildings (Purpose Groups 2-7)

Location of cavity	Class of surface/product exposed in cavity (excluding the surface of any pipe, cable or conduit, or any insulation to any pipe)		Maximum dimensions in any direction (m)
	National class	European class	
Between roof and a ceiling	Any	Any	20
	Class 0 or Class 1	Class A1 or Class A2-s3, d2 or Class B-s3, d2 or Class C-s3, d2	20
Any other cavity	Not Class 0 or Class 1	Not any of the above classes	10

Please note: The façade designer needs to satisfy themselves that the insulation being used complies with the correct European class, i.e. the four listed above. Details of the European class can be obtained from the insulation manufacturer from their Declaration of Performance (DoP), following Construction Products Directives (CPD) and Product Standard EN 13162

Technical specification

Siderise RH 'Open State' horizontal cavity barriers

Form supplied	1200mm long. Supplied pre-cut in width to suit advised void size and complete with brackets if applicable
Colour	Horizontal - RH25(G/S) - black leading edge / green, orange, purple, yellow or grey coloured identification tape (see page 3) Horizontal - RH50(G/S) - black leading edge / red or blue identification tape
Finish	Aluminium foil to top and bottom surfaces
Density	Nominal 75Kg/m ³
Thermal conductivity	$\lambda = 0.038 \text{ W/ m.K}$ (foil to foil)
Void sizes	RH25-90/30 permissible for voids up to 400mm + 25mm air gap = 425mm o/a void RH25-60/60 permissible for voids up to 400mm + 25mm air gap = 425mm o/a void RH25-90/60 permissible for voids up to 275mm + 25mm air gap = 300mm o/a void RH25-120/60 permissible for voids up to 400mm + 25mm air gap = 425mm o/a void RH25-120/90 permissible for voids up to 400mm + 25mm air gap = 425mm o/a void RH50-30/30 permissible for voids up to 250mm + 50mm air gap = 300mm o/a void RH50-60/60 permissible for voids up to 250mm + 50mm air gap = 300mm o/a void
Fire resistance	For product fire performance see Tables 1, 2 and 3
Reaction to fire	The primary stonewool seal is Euro Class 'A1' The reactive intumescent along the leading edge is Euro Class 'E'

Siderise RV vertical cavity barriers

Form supplied	1200mm long. Supplied pre-cut in width to suit advised void size and complete with brackets if applicable or in sheets of 1200 x 1200mm and brackets to be ordered separately
Colour	No colour. Stonewool exposed to leading edge
Finish	Aluminium foil to top and bottom surfaces
Density	Nominal 75Kg/m ³
Thermal conductivity	$\lambda = 0.038 \text{ W/ m.K}$ (foil to foil)
Void sizes	RV-90/30 permissible for voids up to 450mm RV-90/60 permissible for voids up to 450mm RV-120/120 permissible for voids up to 450mm
Fire resistance	For product fire performance see Table 7
Reaction to fire	Euro Class 'A1'

Environmental

Siderise RV and RH Systems are environmentally friendly:

- They contain no Volatile Organic Compounds (VOCs) and no very Volatile Organic Compounds (vVOCs).
- Zero Ozone Depleting Potential
- Zero Global Warming Potential
- Recyclable

Additional information

The following information is available upon request or via download from the website:

- NBS Specification Clause
- Safety Data Sheet
- Installation instructions

Products available

The following Siderise products are available.

Siderise RH 'Open State' horizontal cavity barriers – RH50(G/S) and RH25(G/S)

Siderise RV vertical cavity barriers

Siderise Aluminium Jointing Tape must be used at all joints and intersections: RFT120/45 (120mm wide x 45m rolls) Adhesive backed, Supplied in boxes of 8

Siderise Fire & Acoustic Sealant may be used for small gaps and undulations: FS120/310ML/WH (310ml cartridge) Supplied in boxes of 25

Specification support

Siderise offer specifiers support from initial enquiry and technical consultation to project realisation. NBS draft specifications are provided for standard products and applications and can be tailored to suit specific project performance requirements.

Technical & Sales support

Sales support

Sales Team

T: +44 (0) 1656 730833

E: salesteam@siderise.com

Technical support

Technical Services Team

T: +44 (0) 1656 730833

E: technical.services@siderise.com

Site Services support

Siderise offer a range of services to contractors and installers. These include toolbox product installation and site installation inspection and reporting (subject to availability and by agreement).

Site Services Team

T: +44 (0) 1656 730833

E: site.services@siderise.com

System testing support

Siderise can provide assistance and advice for large scale system testing to BS EN, NFPA, ASTM and AS standards.

Testing Support Team

T: +44 (0) 1656 730833

E: firetesting@siderise.com

Context

The information in this datasheet is believed to be accurate at the date of publication. Siderise has a policy of continuous product improvement and reserves the right to alter or amend the specifications of products without prior notice. Siderise does not accept responsibility for the consequences of using the products described outside of the recommendations within this datasheet. Expert advice should be sought where there is any doubt about the correct specification or installation of Siderise products.



Discovery Quay, Manchester

BY YOUR SIDE®

Siderise Insulation

Passive fire solutions for the building envelope

United Kingdom

Siderise Group, Forge Industrial Estate,
Maesteg, UK, CF34 0AY

T: +44 (0) 1656 730833 | F: +44 (0) 1656 812509

Middle East & India

Siderise Middle East Fz LLC, Office 132,
Al Shafar Investment Building,
Al Quoz Industrial Area 1, Dubai, UAE

T: +971 (0) 4 580 4999

Asia Pacific

Siderise (Asia Pacific) Pte. Ltd. 80 Robinson Road,
#02-00 Singapore 068898

T: +65-963 19310

www.siderise.com

Siderise Special Products

Engineered acoustic solutions for equipment manufacture and construction

Siderise (Special Products) Ltd

Lady Lane Industrial Estate
Hadleigh, Suffolk, IP7 6BQ

T: +44 (0) 1473 827695

